

Direct Drive Free Spooling 760-C and 760-D

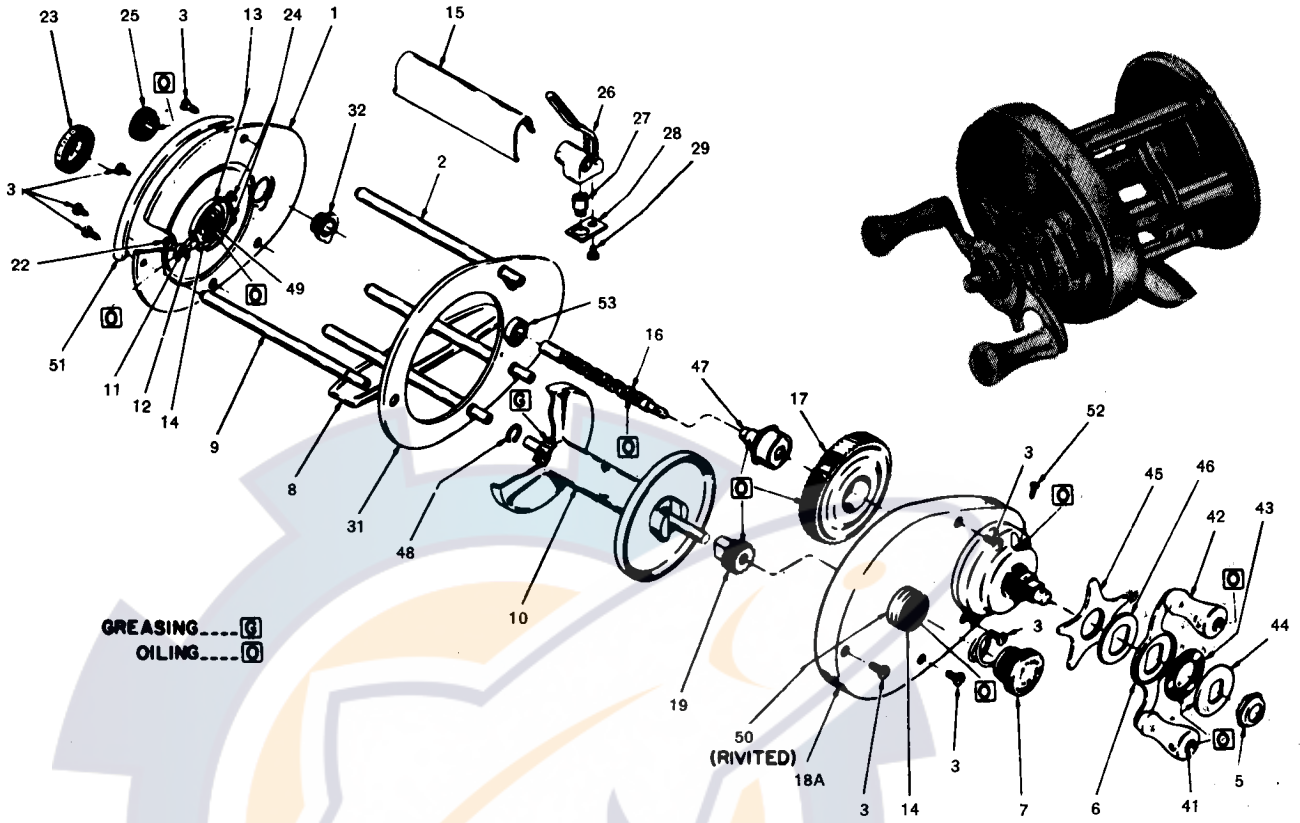

Diagram No.	Part Name	Reel 760-C			Reel 760-D		
		Part No.		Price	Part No.		Price
1	Tail Plate Assembly	RF-36	B1241K	\$1.75	RF-36	B1241K	\$1.75
2	Top Pillar	RA-33	B840K	.35	RA-33	B840K	.35
3	Pillar Screw	R-18		.03	R-18		.03
5	Crank Nut	RJ-11		.25	RJ-11		.25
6	Crank Drag Assembly	RJ-12	B5242K	1.25	RJ-12	B5242K	1.25
7	Head Spool Cap Assembly	RH-20	B1240K	.45	RH-20	B1240K	.45
8	Rod Clip	RC-31	B1242K	.85	RC-31	B1242K	.85
9	Side Pillar	RA-32		.30	RA-32		.30
10	Spool Assembly	RV-19	E698	4.00	RV-19	E698	4.00
11	Click Button Stem	RA-26	E340	.02	RA-26	E340	.02
12	Click Pawl	R-9	P8620	.05	RA-26	P8620	.05
13	Click Spring	RB-10	P85286	.10	RB-9	P85286	.10
14	Spool Bushing	R-45	B920K	.15	RB-10	P85286	.10
15	Line Protector	R-21	B928K	.20	R-45	B920K	.15
16	Line Carriage Screw	RJ-7	N5439	.55	R-21	B928K	.20
17	Drive Gear	RS-15		.75	RJ-7	N5439	.55
18	Head Cap Assembly	RF-28		2.95	RS-15		.75
18	Head Cap Sub Assembly	RF-28A	N5183	6.80	RF-28		2.95
19	Spool Pinion	RL-17	B708K	.35	RF-28A	N5183	6.80
22	Click Button	R-37	B5298KQ	.10	RM-17	B708K	.35
23	Tail Spool Cap Assembly	RH-20T		.65	R-37	B5298KQ	.10
24	Click Spring Rivet	C-43		.03	RH-20T		.65
25	Carriage Screw Busing Cap	B962K		.03	C-43		.03
26	Line Carriage	RA-25	MB954K	.45	RA-25	MB954K	.45
27	Carriage Pawl	RA-3	E2551CA	.55	RA-3	E2551CA	.55
28	Carriage Pawl Retainer	R-4	B1022K	.15	R-4	B1022K	.15
29	Carriage Pawl Retainer Screw	R-5	B1012K	.05	R-5	B1012K	.05
31	Head Ring Assembly	R6		.03	R-6		.03
32	Carriage Screw Tail Bushing	RF-29	B958N	2.10	RF-29	B958N	2.10
		R-24		.20	R-24		.20
41	Crank Stud	R-40	B313K	.10	R40	B313K	.10
42	Crank Handle	R-39	FR5336	.30	R-39	FR5336	.30
43	Crank Drag Washer	R-41	B5417K	.15	R-41	B5417K	.15
44	Drag Plate	R-42	B5321K	.20	R-42	B5321K	.20
45	Crank Drag Star	R-43		.65	R-43		.65
46	Crank Drag Spring Washer	CB-54	B5442K	.15	CB-54	B5442K	.15
47	Gear Driver Assembly	R-44		.70	R-44		.70
48	Ratchet Retaining Ring	R-51	B5258K	.02	R-44		.70
49	Spool Bushing Holder Tail	RB-35T	B5287	.40	RB-35T	B5287	.40
50	Spool Bushing Holder Head	RA-35H	3765	.15	RA-35H	3765	.15
51	Palm Rest	R-46	B-555K	.40	R-46	B-555K	.40
52	Oiler Screw	R-2	NE5444	.03	R-2	NE5444	.03
53	Carriage Screw Bushing Head	R-47		.25	R-47		.25

DISASSEMBLY and ASSEMBLY INSTRUCTIONS

1. To disassemble reel, remove head pillar screws and head plate (cap) assembly. Remove spool assembly and drive gear. 2. To take apart the level wind mechanism, remove carriage screw bushing cap assembly which will allow disassembly of carriage screw and carriage assembly. 3. Wash all parts carefully, using gasoline, or other grease solvents. Replace worn parts. For greasing and oiling see diagrams and instructions.

Numbers shown in red common to both South Bend and Shakespeare.

NOTE: When ordering parts, give reel part name, reel number and model.